



## 1.25Gb/s RoHS Compliant Pluggable CWDM SFP Transceiver

# APSCxx123xxL40

### Product Features

- Up to 1.25Gb/s data links
- Duplex LC connector
- Hot-pluggable SFP footprint
- Uncooled DFB laser transmitter in 18 possible CWDM wavelengths
- RoHS compliant and Lead Free
- Up to 40km on 9/125um SMF
- Metal enclosure for lower EMI
- Single +3.3V power supply
- Low power dissipation <800mW
- Commercial operating temperature
- SFP MSA SFF-8074i Compliant

### Applications

- Gigabit Ethernet
- 1x Fibre Channel

### General

ATOP's APSCxx123xxL40 Small Form Factor Pluggable (SFP) transceivers are compatible with the Small Form Factor Pluggable Multi-Sourcing Agreement (MSA). The SFP transceivers are high performance, cost effective modules supporting dual data-rate of 1.25Gbps/1.063Gbps and 40km transmission distance with SMF. They are RoHS compliant and lead-free.

### Product Selection

Part Number	Operating temperature	DDMI
APSCxx123CXL40	Commercial	No
APSCxx123CDL40	Commercial	Yes

## Wavelength Selection

<b>xx</b>	<b>Wavelength</b>	<b>Clasp Color Code</b>	<b>Receiver Type</b>
27	1270	Blue	PIN
29	1290	Blue	PIN
31	1310	Blue	PIN
33	1330	Blue	PIN
35	1350	Blue	PIN
37	1370	Blue	PIN
39	1390	Blue	PIN
41	1410	Blue	PIN
43	1430	Blue	PIN
45	1450	Blue	PIN
47	1470	Gray	PIN
49	1490	Violet	PIN
51	1510	Blue	PIN
53	1530	Green	PIN
55	1550	Yellow	PIN
57	1570	Orange	PIN
59	1590	Red	PIN
61	1610	Brown	PIN

## Regulatory Compliance

- ESD to the Electrical PINs: compatible with MIL-STD-883 Method 3015
- ESD to the Duplex LC Receptacle: compatible with IEC 61000-4-2
- Immunity compatible with IEC 61000-4-3
- EMI compatible with FCC Part 15 Class B EN55022 Class B (CISPR 22B) VCCI Class B
- Laser Eye Safety compatible with FDA 21CFR 1040.10 and 1040.11 EN60950, EN (IEC) 60825-1,2
- RoHs compliant with 2002/95/EC 4.1&4.2 2005/747/EC

## Pin Descriptions

Pin	Symbol	Name/Description	Ref.
1	VeeT	Transmitter Ground (Common with Receiver Ground)	1
2	TX Fault	Transmitter Fault.	
3	TX Disable	Transmitter Disable. Laser output disabled on high or open.	2
4	MOD_DEF(2)	Module Definition 2. Data line for Serial ID.	3
5	MOD_DEF(1)	Module Definition 1. Clock line for Serial ID.	3
6	MOD_DEF(0)	Module Definition 0. Grounded within the module.	3
7	Rate Select	No connection required	
8	LOS	Loss of Signal indication. Logic 0 indicates normal operation.	4
9	VeeR	Receiver Ground (Common with Transmitter Ground)	1
10	VeeR	Receiver Ground (Common with Transmitter Ground)	1
11	VeeR	Receiver Ground (Common with Transmitter Ground)	1
12	RD-	Receiver Inverted DATA out. AC Coupled	
13	RD+	Receiver Non-inverted DATA out. AC Coupled	
14	VeeR	Receiver Ground (Common with Transmitter Ground)	1
15	VccR	Receiver Power Supply	
16	VccT	Transmitter Power Supply	
17	VeeT	Transmitter Ground (Common with Receiver Ground)	1
18	TD+	Transmitter Non-Inverted DATA in. AC Coupled.	
19	TD-	Transmitter Inverted DATA in. AC Coupled.	
20	VeeT	Transmitter Ground (Common with Receiver Ground)	1

### Notes:

1. Circuit ground is internally isolated from chassis ground.
2. Laser output disabled on TX Disable >2.0V or open, enabled on TX Disable <0.8V.
3. Should be pulled up with 4.7k - 10kohms on host board to a voltage between 2.0V and 3.6V. MOD\_DEF(0) pulls line low to indicate module is plugged in.
4. LOS is open collector output. Should be pulled up with 4.7k – 10kohms on host board to a voltage between 2.0V and 3.6V. Logic 0 indicates normal operation; logic 1 indicates loss of signal.

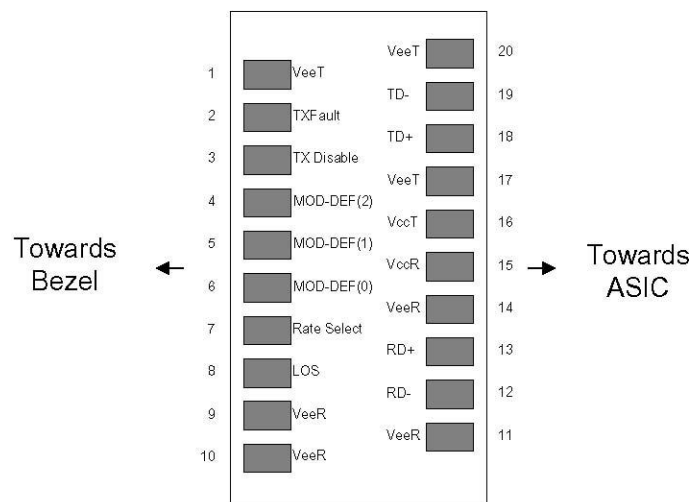

**Pin-out of Connector Block on Host Board**

## Recommend Circuit Schematic

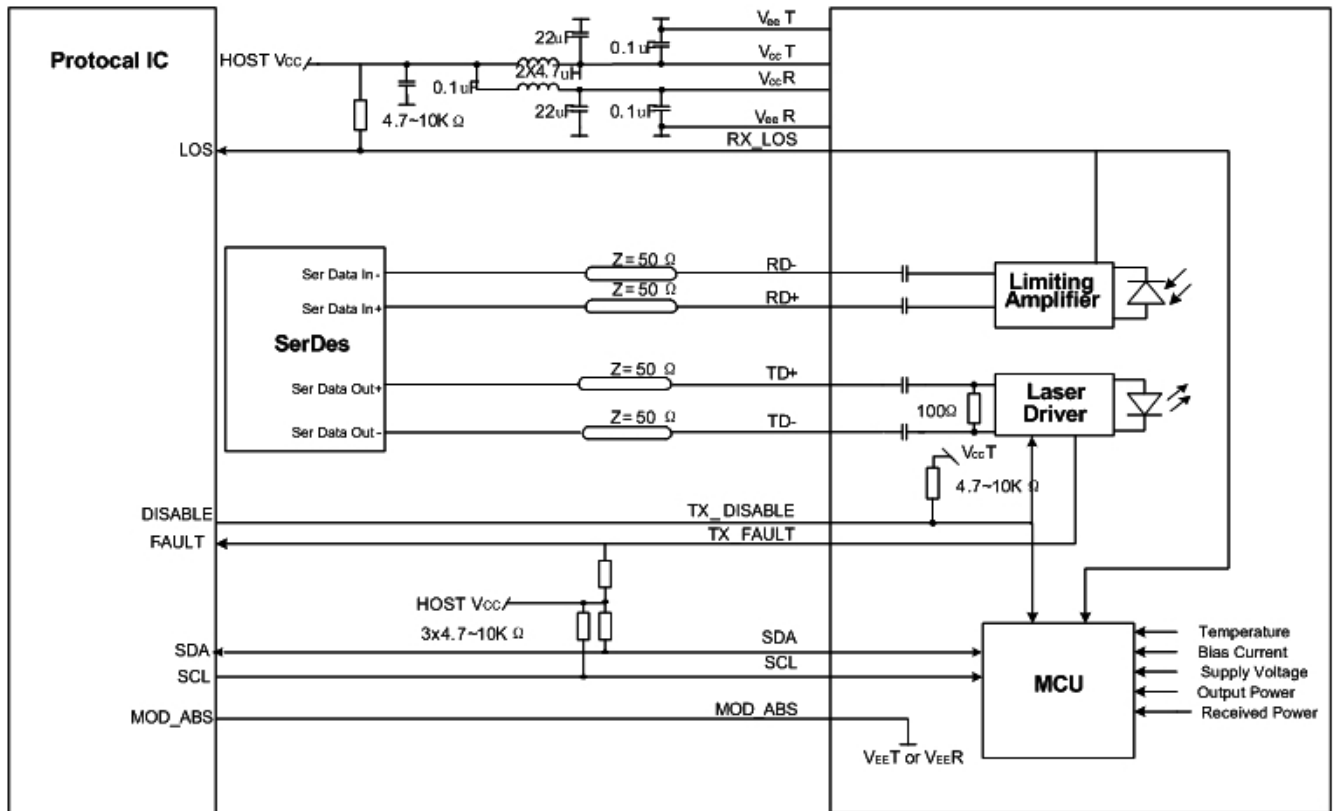

## Absolute Maximum Ratings

Parameter	Symbol	Min	Typ	Max	Unit	Ref.
Maximum Supply Voltage	Vcc	-0.5	-	+4.0	V	
Storage Temperature	TS	-40	-	+85	°C	
Operating Humidity	RH	5	-	95	%	

## Recommended Operating Conditions

Parameter	Symbol	Min	Typ	Max	Unit	Ref.
Power Supply Voltage	Vcc	3.13	3.30	3.47	V	
Power Supply Current	Icc	-	-	250	mA	
Case Operating Temperature	Tc	0	-	+70	°C	
Data Rate(Gigabit Ethernet)	-	-	1.25	-	Gbps	
Data Rate(Fibre Channel)	-	-	1.063	-	Gbps	
9/125um G.652 SMF	Lmax	-	-	40	km	

## Electrical Characteristics (TOP=25°C, Vcc=3.3Volts)

Parameter	Symbol	Min	Typ	Max	Unit	Ref.
<b>Transmitter</b>						
Input differential impedance	Rin	-	100	-	Ω	1
Single ended data input swing	Vin, pp	250	-	1200	mV	
TX Disable-High	-	Vcc – 1.3	-	Vcc	V	
TX Disable-Low	-	Vee	-	Vee+ 0.8	V	
TX Fault-High	-	Vcc-0.5	-	Vcc	V	
TX Fault-Low	-	Vee	-	Vee+0.5	V	
<b>Receiver</b>						
Single ended data output swing	Vout, pp	300	400	800	mV	2
Data output rise time	tr	-	-	175	ps	3
Data output fall time	tf	-	-	175	ps	3
LOS-High	-	Vcc – 0.5		Vcc	V	
LOS-Low	-	Vee		Vee+0.5	V	

### Notes:

1. AC coupled.
2. Into 100 ohm differential termination.
3. 20 – 80 %

## Optical Characteristics (TOP=25°C, Vcc=3.3 Volts)

Parameter	Symbol	Min	Typ	Max	Unit	Ref.
<b>Transmitter</b>						
Output Opt. Power	PO	-5	-	0	dBm	1
Optical Wavelength	$\lambda$	x-4	x	x+7	nm	2
Spectral Width	$\sigma$	-	-	1	nm	
Side Mode Suppression Ratio	SMSR	30	-	-	dB	
Optical Rise/Fall Time	tr/tf	-	-	260	ps	3
Total Jitter	TJ	-	-	200	ps	
Optical Extinction Ratio	ER	9	-	-	dB	
<b>Receiver</b>						
RX Sensitivity @ 1.25 Gb/s	RSENS	-	-	-25	dBm	4
Maximum Received Power	RXMAX	0	-	-	dBm	
Optical Center Wavelength	$\lambda_C$	1270	-	1610	nm	
LOS De-Assert	LOSD	-	-	-26	dBm	
LOS Assert	LOSA	-40	-	-	dBm	
LOS Hysteresis	-	0.5	-	5	dB	

### Notes:

1. Class 1 Laser Safety.
2. The Transmitter Center Wavelength "x" is as specified by the customer.
3. Unfiltered, 20-80%. Complies with Gigabit Ethernet eye masks when filtered.
4. Measured with PRBS 2<sup>7</sup>-1 at 10<sup>-10</sup> BER.

## Mechanical Specifications

ATOP's Small Form Factor Pluggable (SFP) transceivers are compatible with the dimensions defined by the SFP Multi-Sourcing Agreement (MSA).

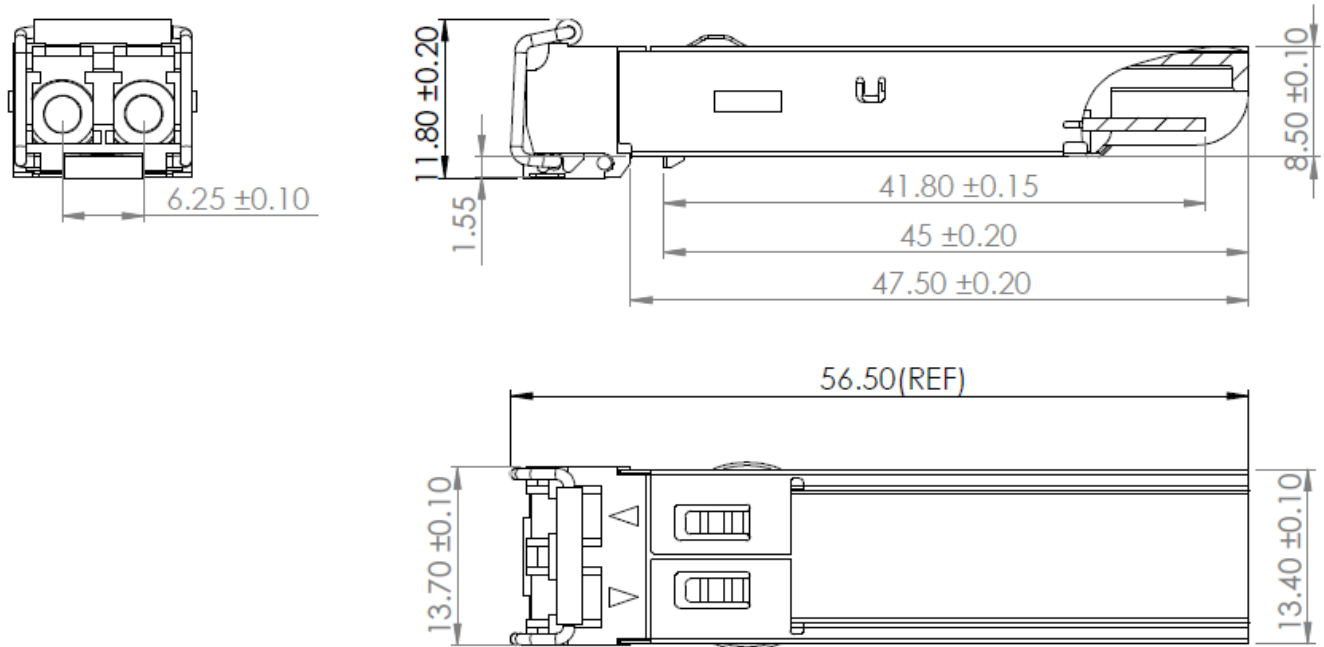

**APSCxx123xxL40**

## EEPROM Information

EEPROM memory map specific data field description is as below:

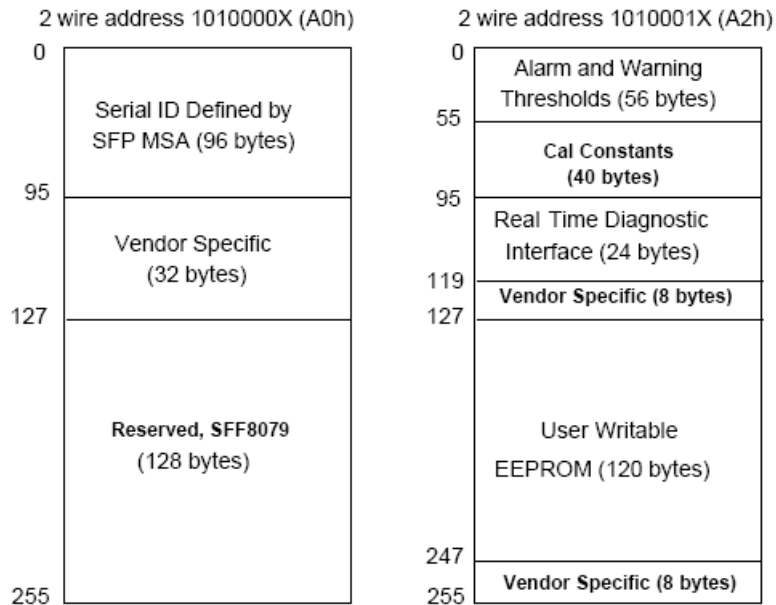

## Digital Diagnostic Monitoring Interface

Five transceiver parameter values are monitored. The following table defines the monitored parameter's accuracy.

Parameter	Range	Accuracy	Calibration
Temperature	0 to +70°C	±3°C	Internal
Voltage	2.97 to 3.63V	±3%	Internal
Bias Current	0 to 100mA	±10%	Internal
TX Power	-5 to 0dBm	±3dB	Internal
RX Power	-25 to 0dBm	±3dB	Internal

## For More Information

ATOP Corporation  
 5A of NO.C building of Tongfang information Harbour, langshan Rd, High Tech Park,  
 Nanshan District, Shenzhen, China.  
 Tel: +86-755-86674946  
 Fax: +86-755-86296723  
 Email: [sales@atoptechnology.com](mailto:sales@atoptechnology.com)  
 Web: [www.atoptechnology.com](http://www.atoptechnology.com)